

HELIX MUST BE FORMED BY MATCHING METAL DIE
(SIDE VIEW OF TRUE HELICAL FORM)

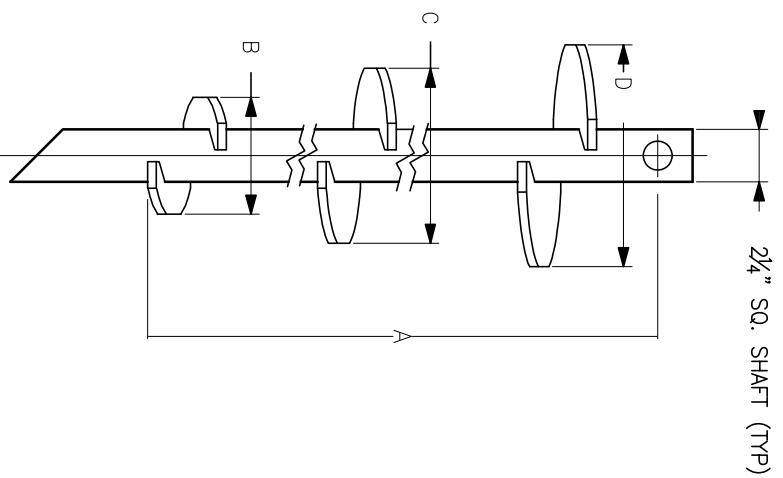

LEAD SECTION

SCALE: N.T.S.

LEAD SECTION			
"A"	"B"	"C"	"D"
5 3/4"	6"	8"	10"
7 1/2"	8"	10"	12"

SS225 HELICAL PILES

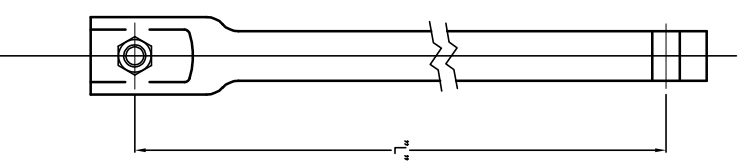

PLAIN EXTENSION

SCALE: N.T.S.

EXTENSION	
"L"	
54"	
74"	
96"	

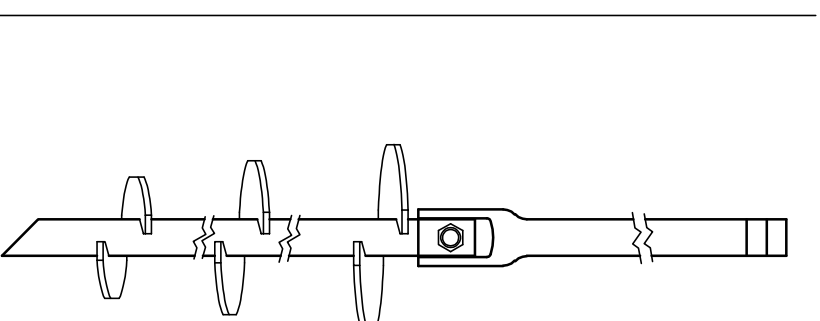

TYPICAL PILE ASSEMBLY

SCALE: N.T.S.

DISCLAIMER

- The information and sketches contained in these drawings are given as guidelines only.
- Capacities of Chance® Helical Piles may vary depending on, but not limited to, water table elevation and changes to that elevation, changing soil conditions, soil layer thicknesses.
- Achievable capacities could be higher or lower than ratings due to site-specific conditions. On-site load testing should be performed to confirm additional pile capacities.
- Installed capacities to be verified by a registered Professional Engineer experienced in Chance® helical pile installation.
- The information contained herein is to be used for preliminary design activities only, and subject to EBS' Website Disclaimer.

NOTES:

- HOT DIP GALVANIZED PER ASTM A153 (LATEST REV.).
- LEAD AND EXTENSION SECTION LENGTHS AND HELIX SPACINGS ARE NOMINAL.
- NOMINAL SPACING BETWEEN HELIX PLATES IS THREE TIMES THE DIAMETER OF THE LOWER HELIX.
- SHAFT MATERIAL-HOT ROLLED ROUND-CORNERED SQUARE (RCS) SOLID STEEL BARS PER ASTM A29; MINIMUM YIELD STRENGTH-80 KSI.
- HELIX MATERIAL-HOT ROLLED LOW CARBON STEEL SHEET, STRIP, OR PLATE PER ASTM A572, OR A1018, OR A656; MINIMUM YIELD STRENGTH=80 KSI; 1/2" THICK.
- COUPLING BOLTS: 1-1/2" DIAMETER X 4-3/4" LONG HEX HEAD PER ASTM A193 GRADE B7.
- MANUFACTURER TO HAVE IN EFFECT INDUSTRY RECOGNIZED WRITTEN QUALITY CONTROL FOR ALL MATERIALS AND MANUFACTURING PROCESSES.
- ALL WELDING TO BE DONE BY WELDERS CERTIFIED UNDER SECTION 5 OF THE AWS CODE D1.1.
- TORQUE STRENGTH RATING - 23000 FT-LBS.
- ULTIMATE CAPACITY (COMPRESSION) - 230kips, BASED ON A TORQUE FACTOR (Kf) = 10
- SINGLE HELIX ULTIMATE STRENGTH - 50kips.
- ULTIMATE CAPACITY (TENSION/COMPRESSION) - 200kips.

NO.	DATE	REVISION

EBS
GEOSTRUCTURAL

320 Woolwich Street South, Breslau, Ontario, N0B 1M0
Tel: 519-648-3613 Fax: 519-648-2526
Email: info@ebsgeo.com

COR IHS A.ca
Member Since 1978

PROJECT: SAMPLE

DRAWING: SS225 HELICAL PILES

DRW'N BY:	SCALE:	N.T.S.
CHECKED:	DATE:	NOVEMBER 2021
PROJECT No.:	DWG. No.:	

EBS is an authorized distributor of A.B. Chance Civil Construction products.
CHANGE
Since 1912
Registered trademark of A.B. Chance, a division of Hubbell Power Systems, Inc.