

DISCLAIMER

1. The information and sketches contained in these drawings are given as guidelines only.
2. Capacities of Chance Helical Piles/Anchors may vary depending on, but not limited to, water table elevation and changes to that elevation, changing soil conditions, soil layer thicknesses.
3. Achievable capacities could be higher or lower than ratings due to site-specific conditions. On site load testing should be performed to confirm additional pile/anchor capacities.
4. Installed capacities to be verified on site by a registered Professional Engineer.
5. The information contained herein is to be used for preliminary design activities only, and subject to EBS' Website Disclaimer.

SS200 HELICAL PIERS / ANCHORS

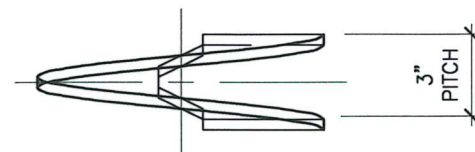

HELIX MUST BE FORMED BY MATCHING METAL DIE
(SIDE VIEW OF TRUE HELICAL FORM)

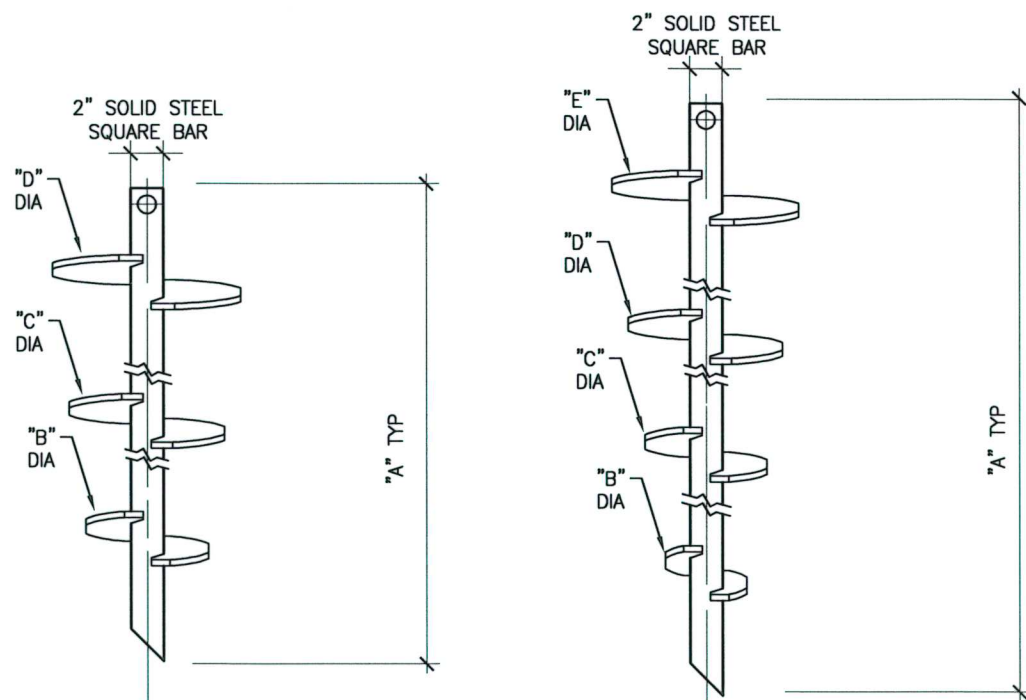

LEAD SECTION

SCALE: N.T.S.

LEAD SECTION				
"A"	"B"	"C"	"D"	"E"
59.25"	6"	8"	10"	
59.25"	8"	10"	12"	
79"	6"	8"	10"	12"

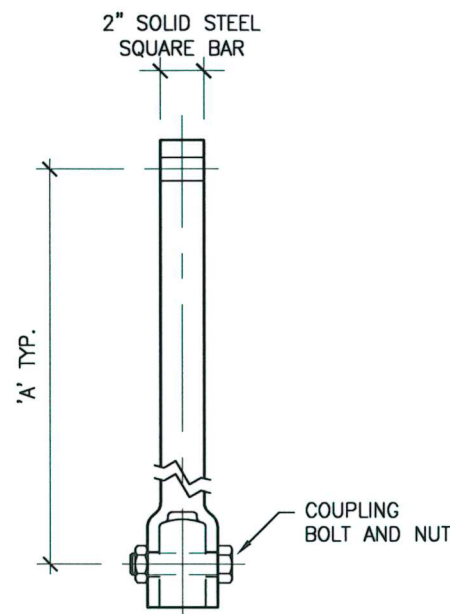

PLAIN EXTENSION

SCALE: N.T.S.

EXTENSION
"A"
58.75"
80.25"
123.25"

NOTES

1. HOT DIP GALVANIZED PER ASTM A153--(LATEST REV.)
2. SHAFT MATERIAL--HOT ROLLED ROUND--CORNERED SQUARE (RCS) SOLID STEEL BARS PER ASTM A29; MINIMUM YIELD STRENGTH=90 KSI.
3. HELIX MATERIAL--HOT ROLLED LOW CARBON STEEL SHEET, STRIP, OR PLATE PER ASTM A656 OR A1018 GRADE 80; MINIMUM YIELD STRENGTH=80 KSI; 1/2" THICK.
4. COUPLING BOLTS: 1.125-7UNC HEX HEAD PER ASTM A193 GRADE B7.
5. NOMINAL SPACING BETWEEN HELICAL PLATES IS THREE TIMES THE DIAMETER OF THE LOWER HELIX.
6. MANUFACTURER TO HAVE IN EFFECT INDUSTRY RECOGNIZED WRITTEN QUALITY CONTROL FOR ALL MATERIALS AND MANUFACTURING PROCESSES.
7. ALL WELDING TO BE COMPLETED BY WELDERS CERTIFIED UNDER SECTION 5 OF THE AWS CODE D1.1.
8. ALL HELICES HAVE A SHARPENED LEADING EDGE.
9. TORQUE STRENGTH RATING--16,000 FT-LB.
10. ULTIMATE CAPACITY (TENSION/COMPRESSION)--160 KIP, BASED ON A TORQUE FACTOR (Kt)--10.
11. ULTIMATE TENSION STRENGTH (COUPLING BOLT) -- 150 KIP.

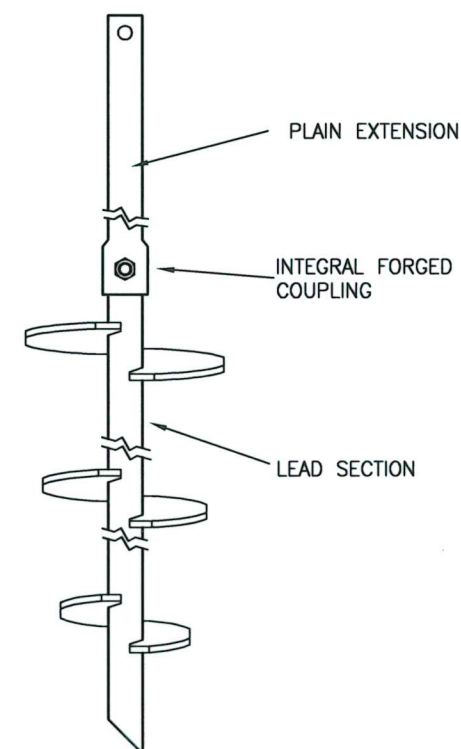

TYPICAL PIER / ANCHOR ASSEMBLY

SCALE: N.T.S.

EBS is an authorized distributor of A.B. Chance Civil Construction products.

CHANCE
Since 1912

Registered trademark of A.B. Chance, a division of Hubbell Power Systems, Inc.



320 Woolwich Street South, Breslau, Ontario N0B 1M0
Tel: 519-648-3613 Fax: 519-648-2526
Email: info@ebsgeo.com

PROJECT: SAMPLE

DRAWING: SS200 HELICAL PIERS / ANCHORS

DRW'N BY:	SCALE: N.T.S.
CHECKED:	DATE: NOVEMBER 2012
PROJECT No.:	DWG. No.: